

PART NO.	BORE SIZE	KEY SIZE
4802-4116	1.0	1/4 X 1/4
4802-4118	1.125	1/4 X 1/4
4802-4120	1.250	1/4 X 1/4
4802-4122	1.375	5/16 X 5/16
4802-4124	1.500	3/8 X 3/8
4802-4126	1.625	3/8 X 3/8
4802-4128	1.750	3/8 X 3/8

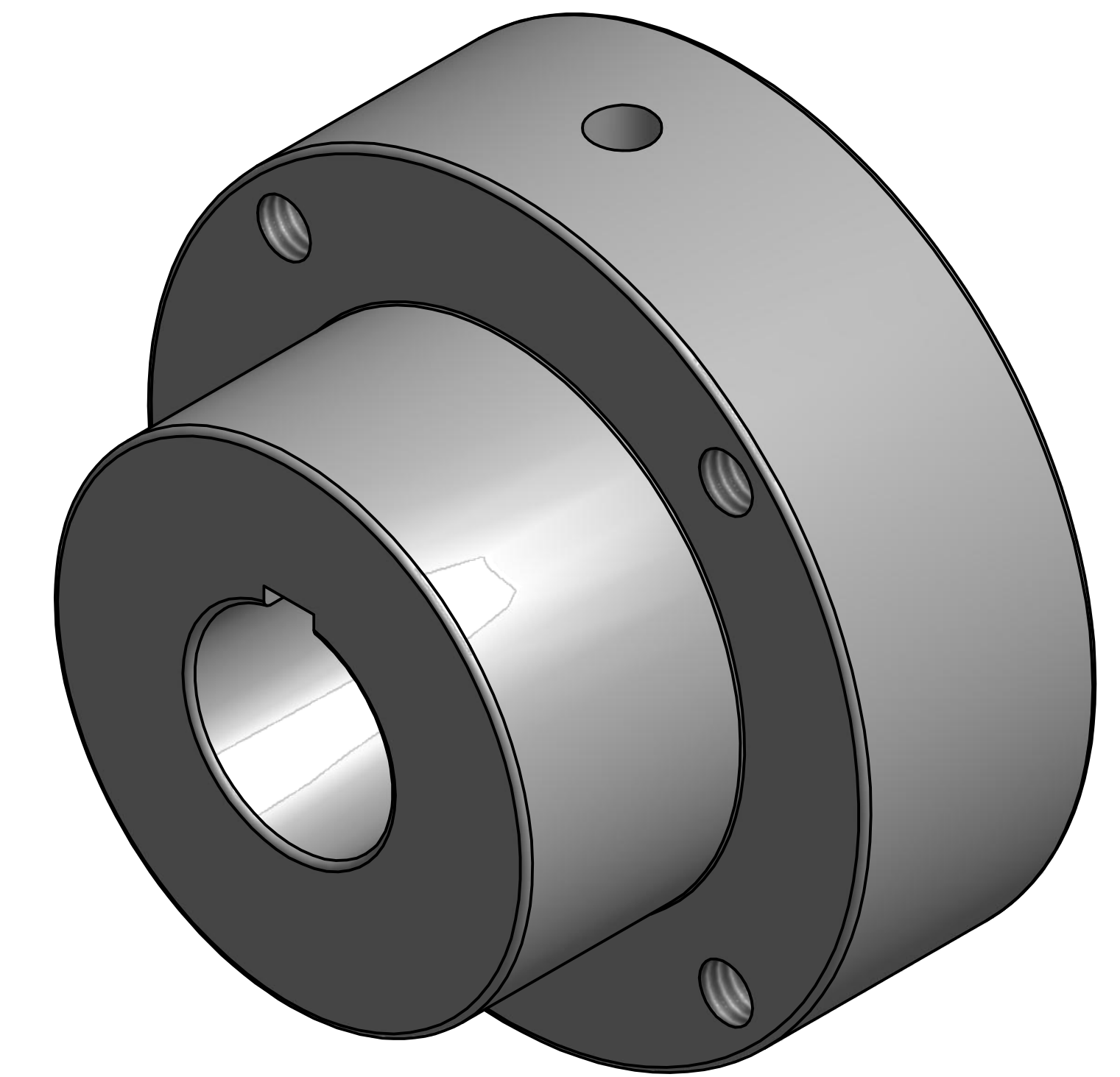

MATERIAL: COLD DRAWN 1215  
 FINISH: BLACK OXIDE  
 BORE TOLERANCE:  $+.002/-0.000$   
 KEYWAY TOLERANCE:  $+.002/-0.000$

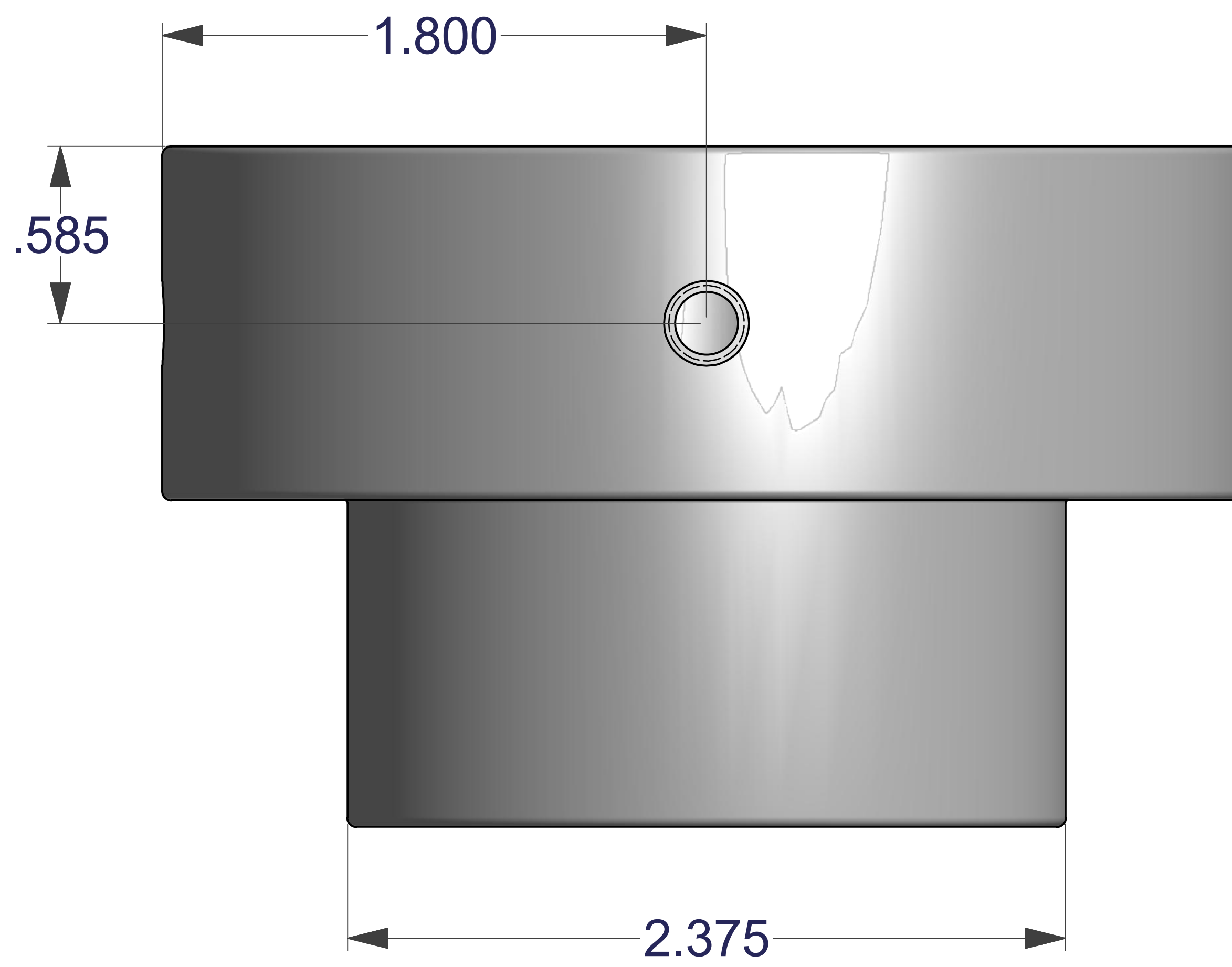
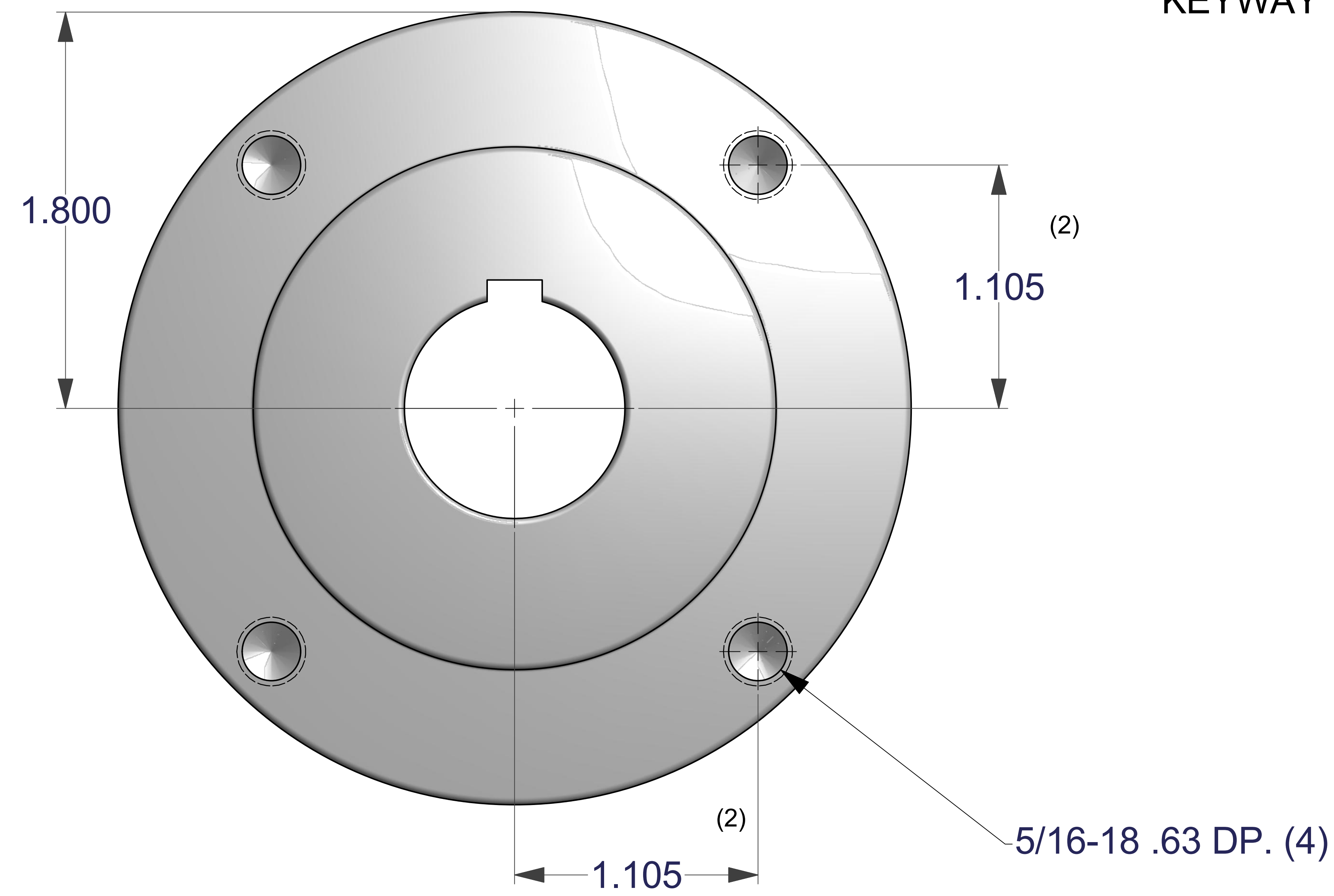
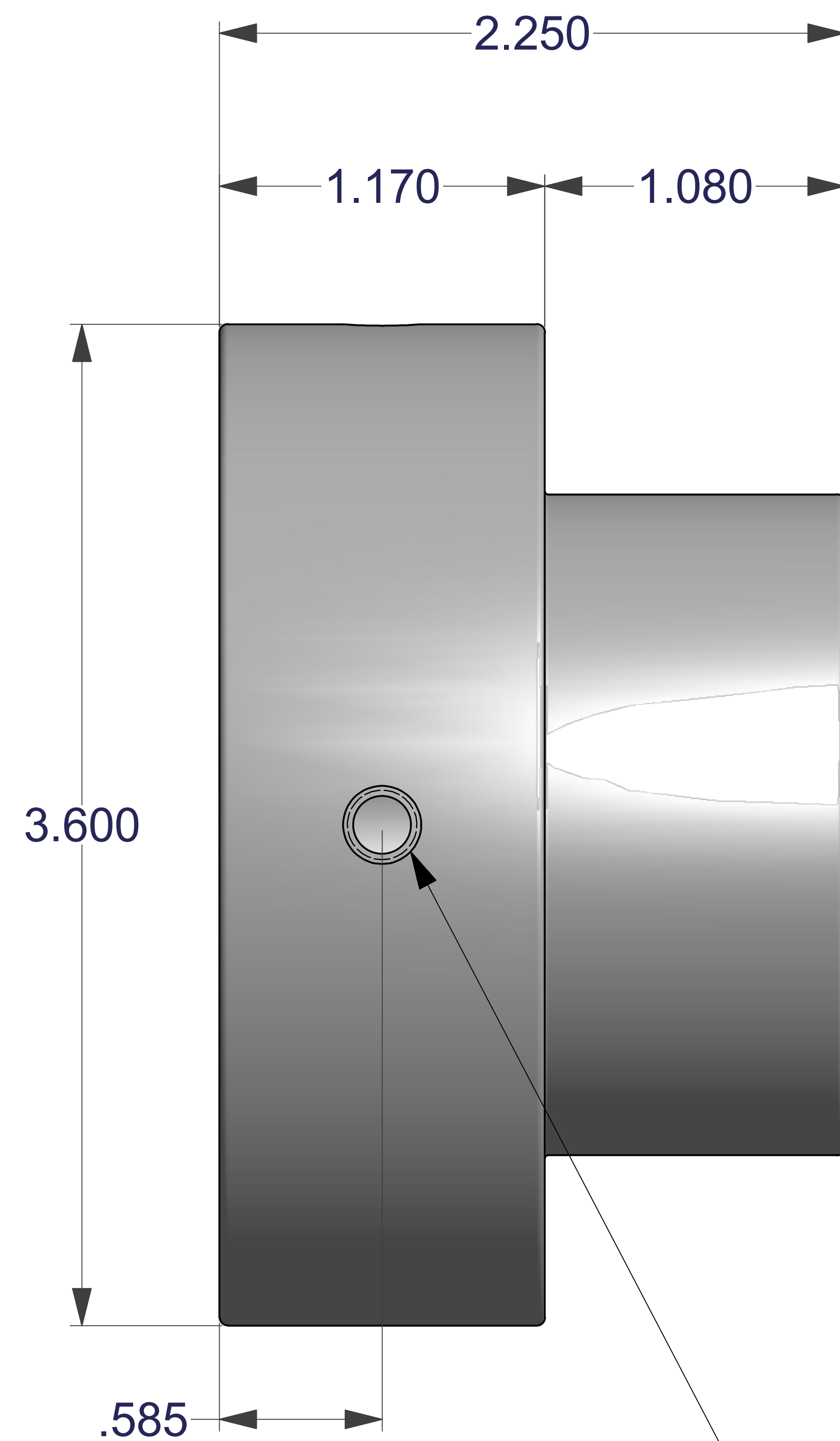

1/4-20 (2) 1.80 DP. (2)

5/16-18 .63 DP. (4)

SIZE  
E

UNLESS OTHERWISE SPECIFIED: DO NOT SCALE DRAWING REMOVE ALL BURRS TAP DEPTHS FULL THD. DRILL DEPTHS FULL DIA.		THIRD ANGLE PROJECTION		W.C. BRANHAM INC. RIVER FALLS, WI.	
TOLERANCES 2 PLACE $\pm .010$ 3 PLACE $\pm .005$		DESIGNER WCB	DATE 08/18/11	TITLE DISC HUBS, 8 & 10 IN. DISCS	
THREADS EXTERNAL CLASS 2A INTERNAL CLASS 2B		CHECKER	DATE	DRAWING NO.	REVISION
		SCALE			
		CLASS			