

INPUT TORQUE = OUTPUT TORQUE / .6
 MAX. HAND TORQUE = 132 IN. LBS.

RPM	TORQUE, IN. LBS.
33	59
50	51
100	41
150	36
200	32
300	28
400	21
500	19
600	18
1,000	15
1,200	14
1,800	12

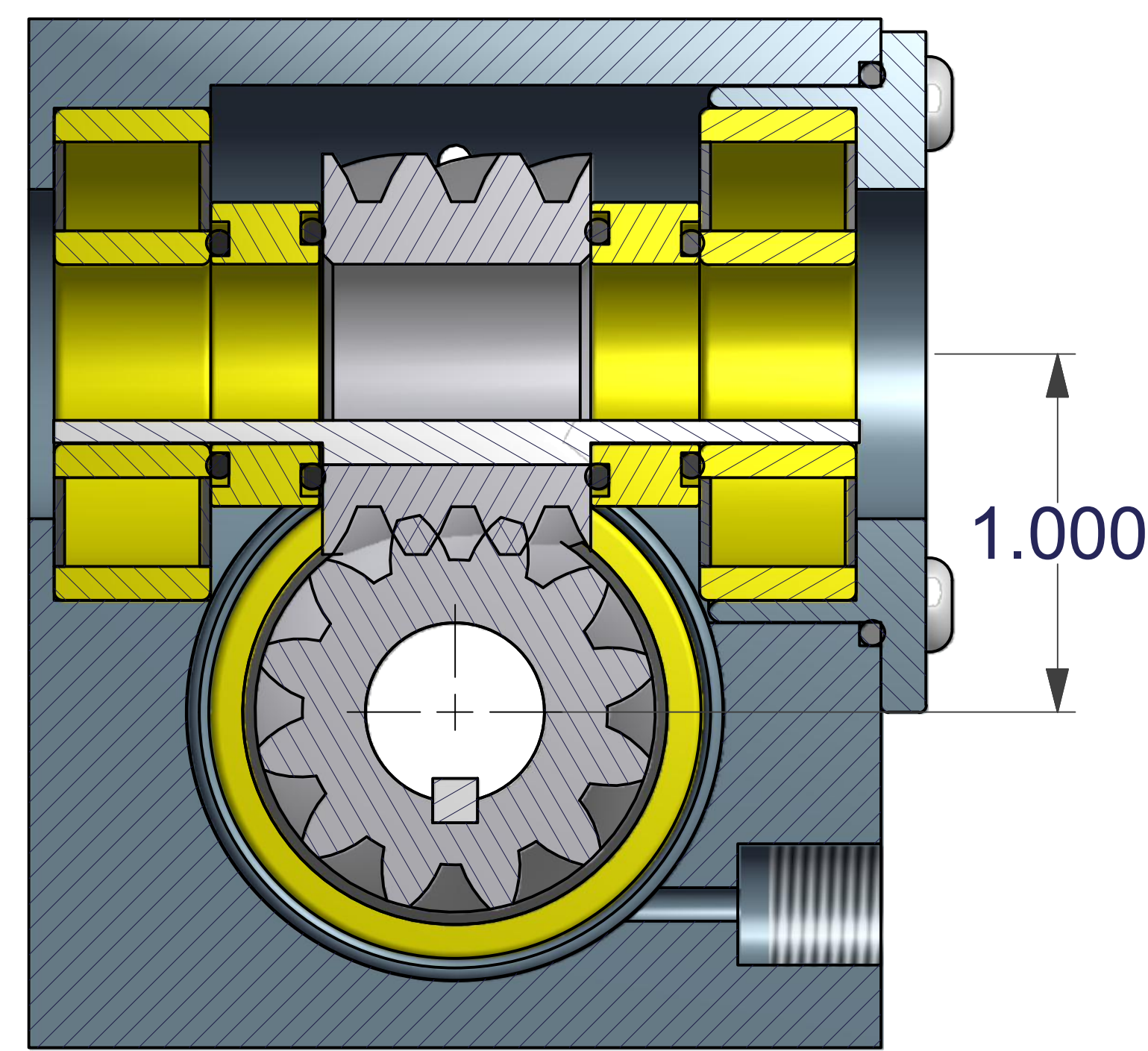

SECTION A-A
SCALE 2.5

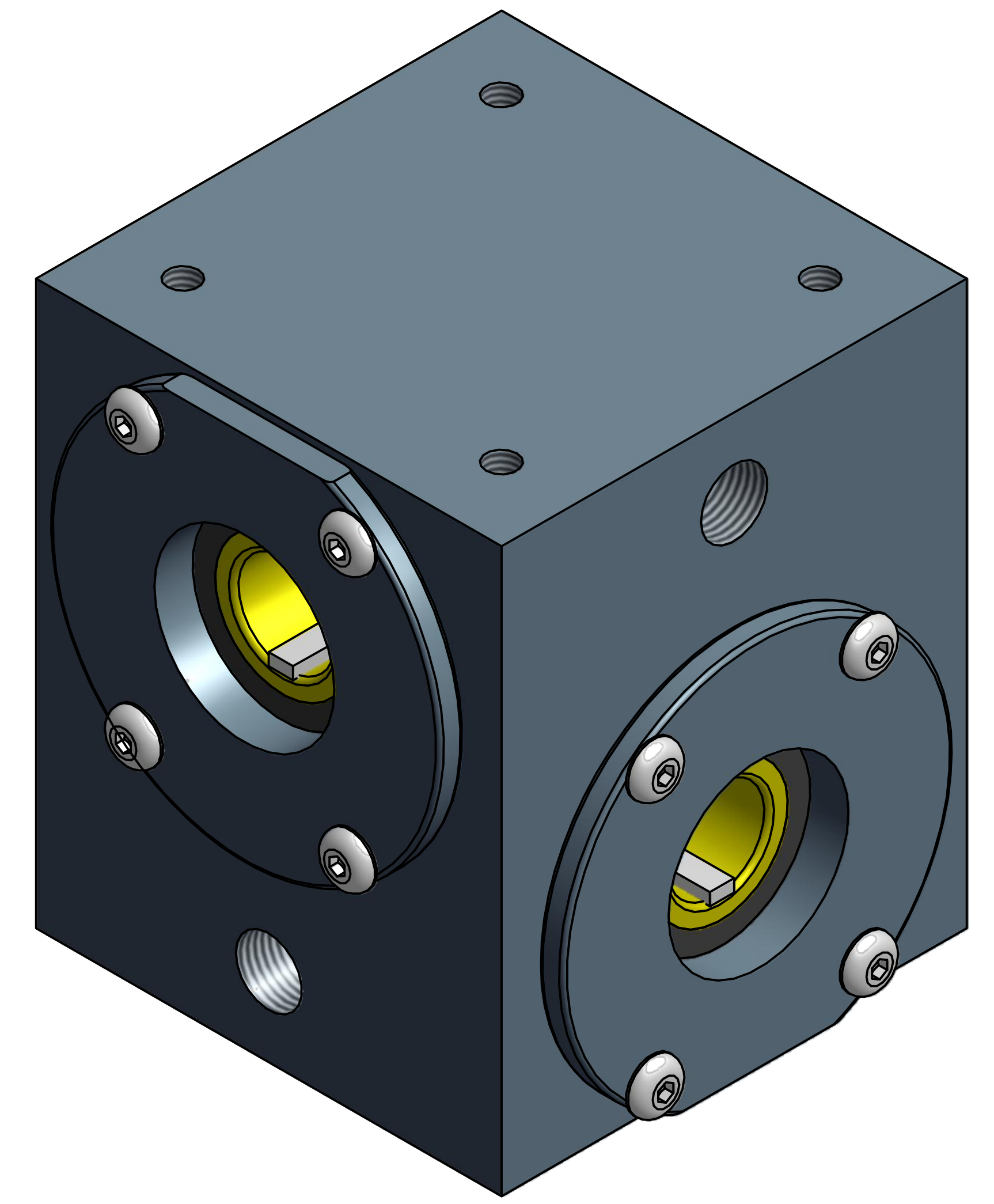
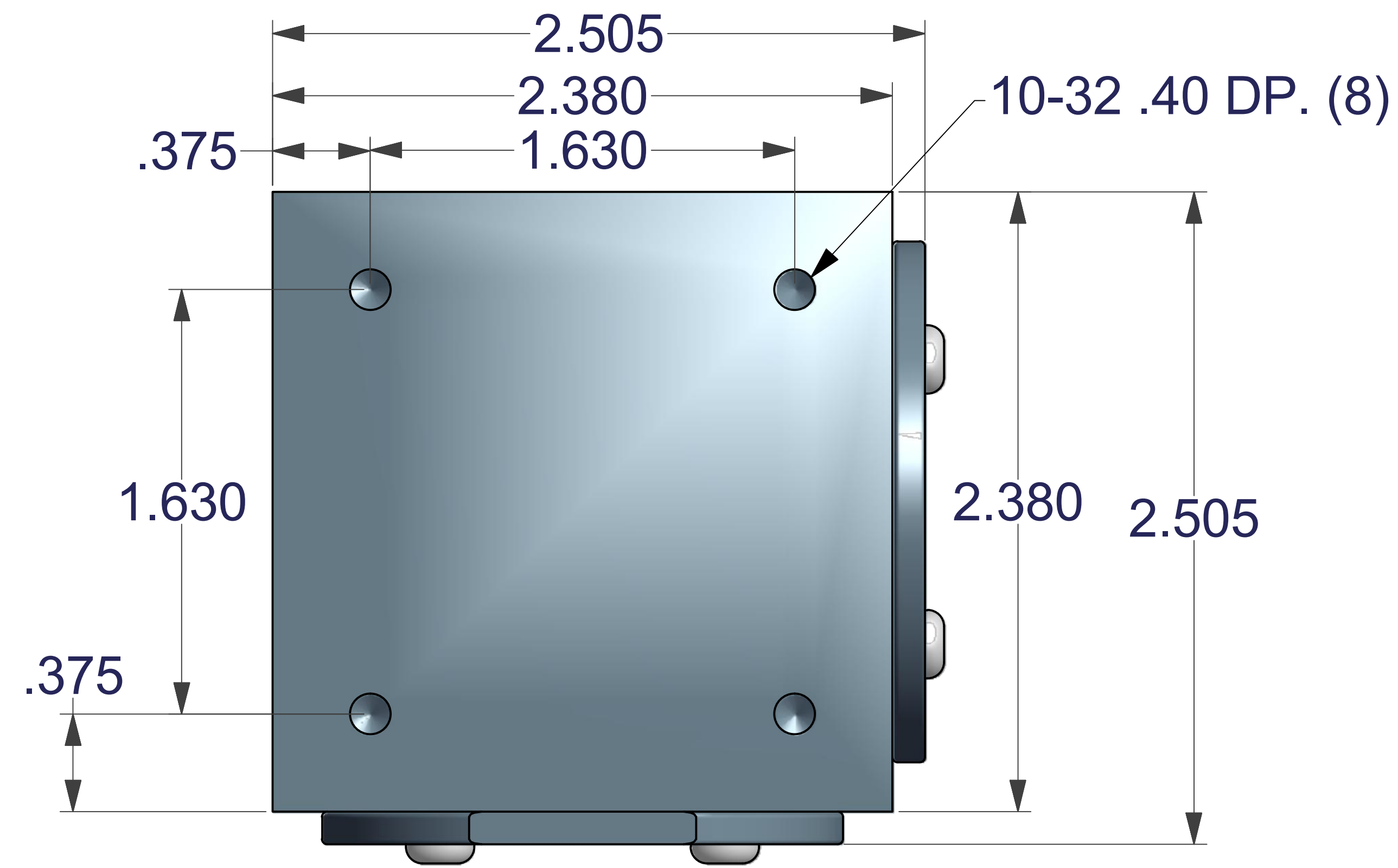
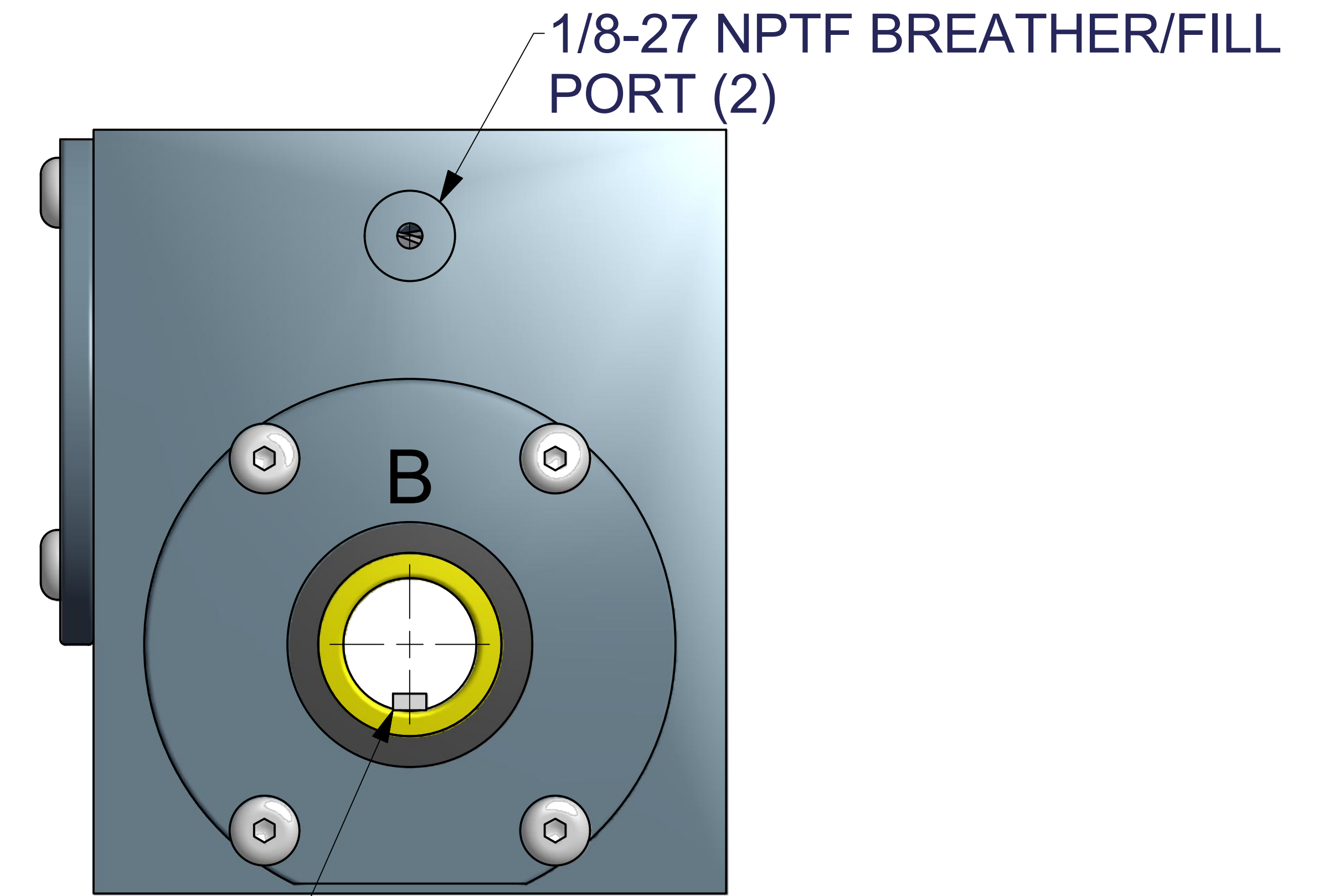
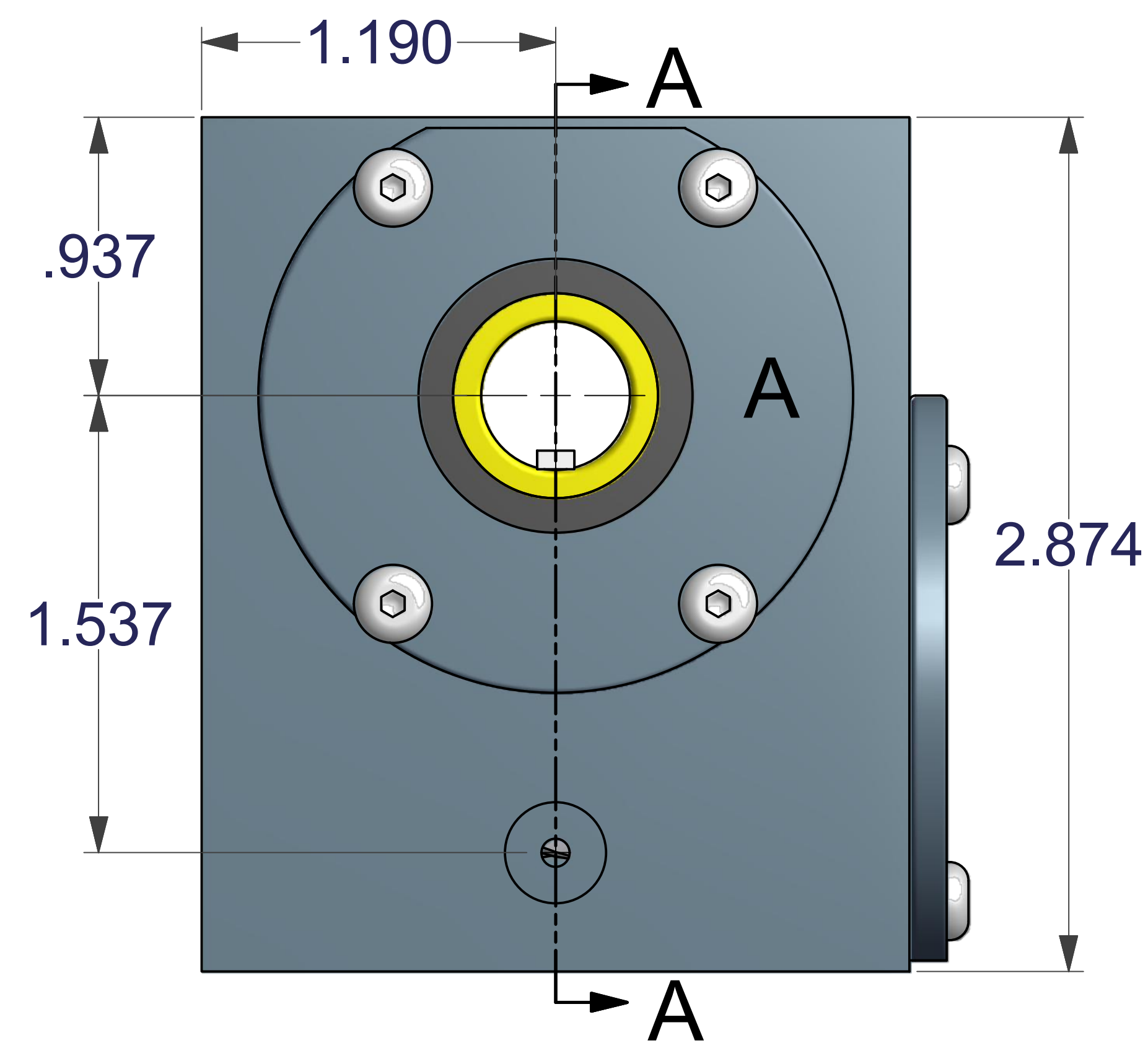

KEY 1/8 X 1/16

- * PREFILLED WITH MAGNALUBE G GRADE 2
- * 8620 HEAT TREATED GEARS
- * (4) R16 DBL. SEALED BALL BEARINGS
- * ALUM. HOUSING & CAPS, ANODIZED

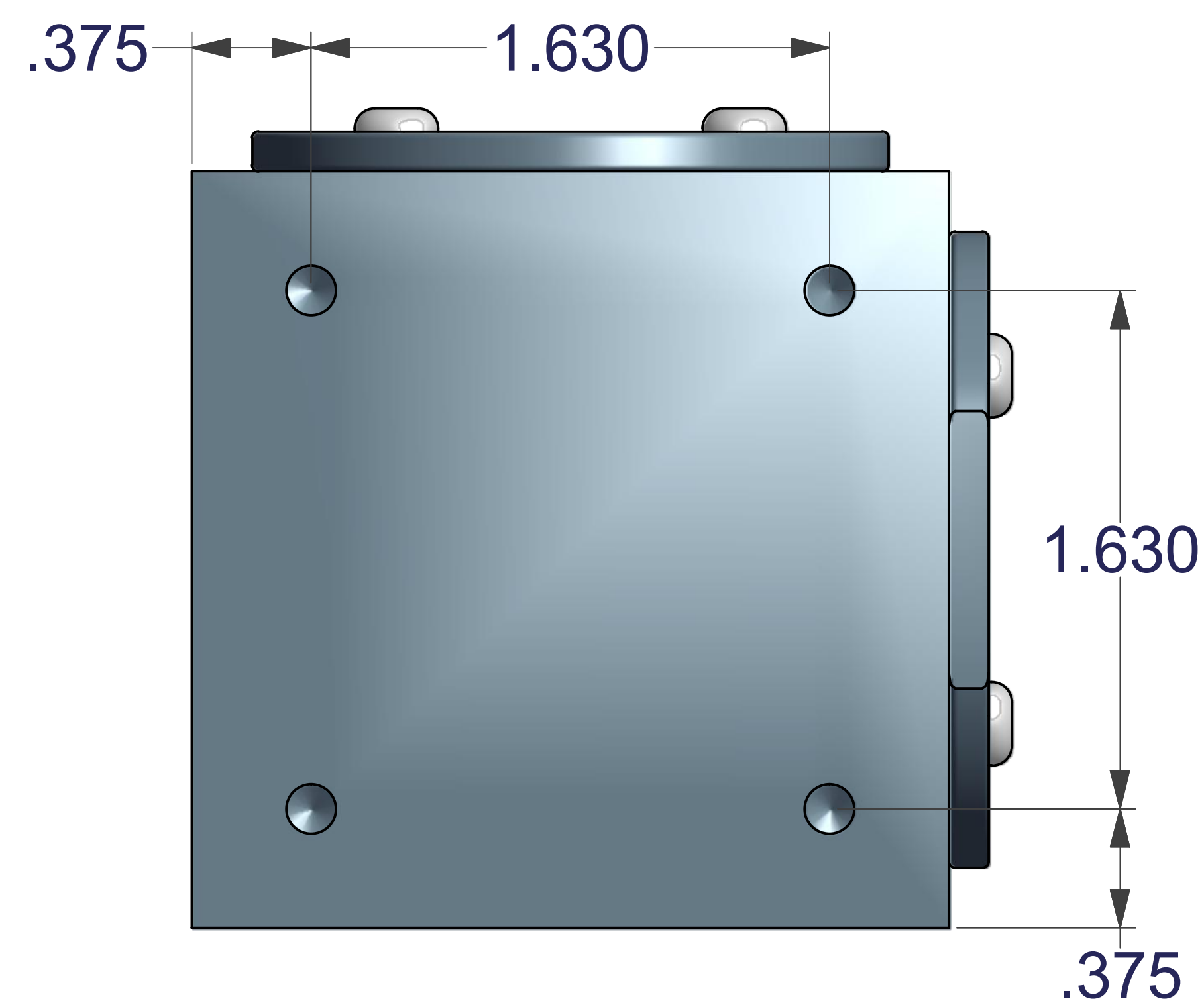

PART NUMBER	TYPE	RATIO	ROTATION	A-BORE	B-BORE
4304-0116	AAS ALL	1:1 ALL	R.H.	5/8	5/8
4304-0117			L.H.	5/8	5/8
4304-0118			R.H.	1/2	5/8
4304-0119			L.H.	1/2	5/8
4304-0120			R.H.	1/2	1/2
4304-0121			L.H.	1/2	1/2

UNLESS OTHERWISE SPECIFIED: DO NOT SCALE DRAWING REMOVE ALL BURRS TAP DEPTHS FULL THD. DRILL DEPTHS FULL DIA.		THIRD ANGLE PROJECTION		WC BRANHAM INC. RIVER FALLS, WI	
TOLERANCES 2 PLACE +/- .010 3 PLACE +/- .005	DESIGNER WCB	DATE 07/19/10	CHECKER	TITLE MINI AAS DIMENSIONAL	DRAWING NO.
THREADS EXTERNAL CLASS 2A INTERNAL CLASS 2B	SCALE	CLASS		REVISION	

E