

| PART NUMBER | RATIO | ROTATION | A-BORE | B-BORE |
|-------------|---------|----------|--------|--------|
| 4306-0020 | 1:1 ALL | R.H. | 5/8 | 5/8 |
| 4306-0021 | | L.H. | 5/8 | 5/8 |
| 4306-0022 | | R.H. | 3/4 | 3/4 |
| 4306-0023 | | L.H. | 3/4 | 3/4 |
| 4306-0024 | | R.H. | 1.0 | 1.0 |
| 4306-0025 | | L.H. | 1.0 | 1.0 |
| 4306-0026 | | R.H. | 5/8 | 3/4 |
| 4306-0027 | | L.H. | 5/8 | 3/4 |
| 4306-0028 | | R.H. | 5/8 | 1.0 |
| 4306-0029 | | L.H. | 5/8 | 1.0 |
| 4306-0030 | | R.H. | 3/4 | 1.0 |
| 4306-0031 | | L.H. | 3/4 | 1.0 |
| 4306-0032 | | R.H. | 3/4 | 5/8 |
| 4306-0033 | | L.H. | 3/4 | 5/8 |
| 4306-0034 | | R.H. | 1.0 | 5/8 |
| 4306-0035 | | L.H. | 1.0 | 5/8 |
| 4306-0036 | | R.H. | 1.0 | 3/4 |
| 4306-0037 | | L.H. | 1.0 | 3/4 |

- * PREFILLED WITH LUBRIPLATE 1500 GRADE 00
- * 8620 HEAT TREATED 20 TOOTH GEARS
- * (4) R20 DBL. SEALED BALL BEARINGS
- * (4) SHAFT SEALS
- * ALUM. HOUSING & CAPS, BLACK ANODIZED
- * ELECTRO NICKEL PLATING & STAINLESS FASTENERS AVAILABLE
- * STAINLESS HOUSINGS, CAPS & BEARINGS AVAILABLE
- * METRIC BORE SIZES & METRIC THREADS AVAILABLE

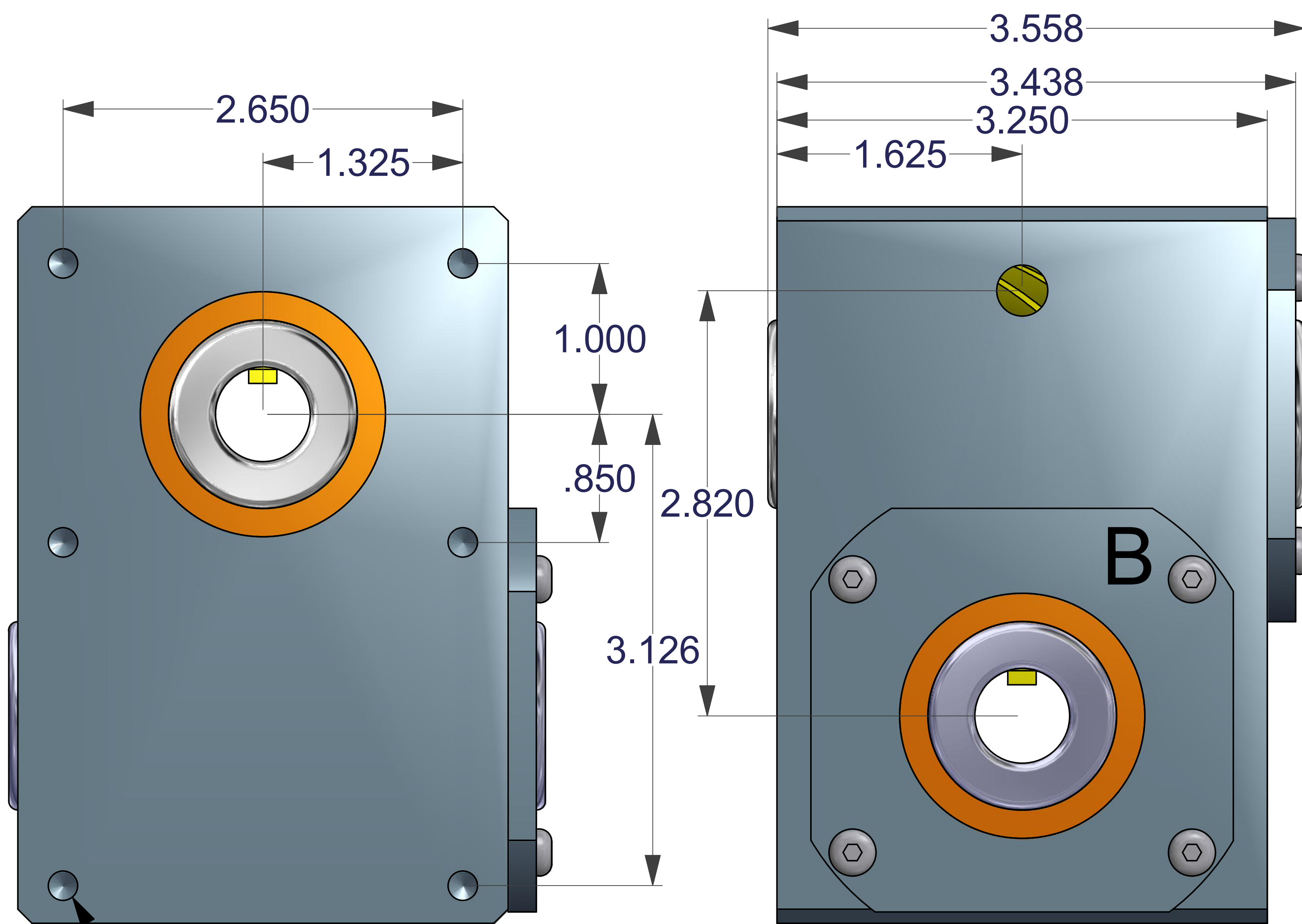

1/4-20 .44 DP. (6)

MAX. HAND TORQUE -- 402 IN. LBS.
 INPUT TORQUE = OUTPUT TORQUE/.6
 RPM OUTPUT TORQUE, IN. LBS.

| | |
|------|-----|
| 33 | 236 |
| 50 | 205 |
| 100 | 163 |
| 200 | 130 |
| 300 | 113 |
| 400 | 80 |
| 500 | 73 |
| 1000 | 59 |
| 1200 | 56 |

KEY SIZES
 5/8 BORE - 3/16
 3/4 BORE - 3/16
 1.0 BORE - 1/4

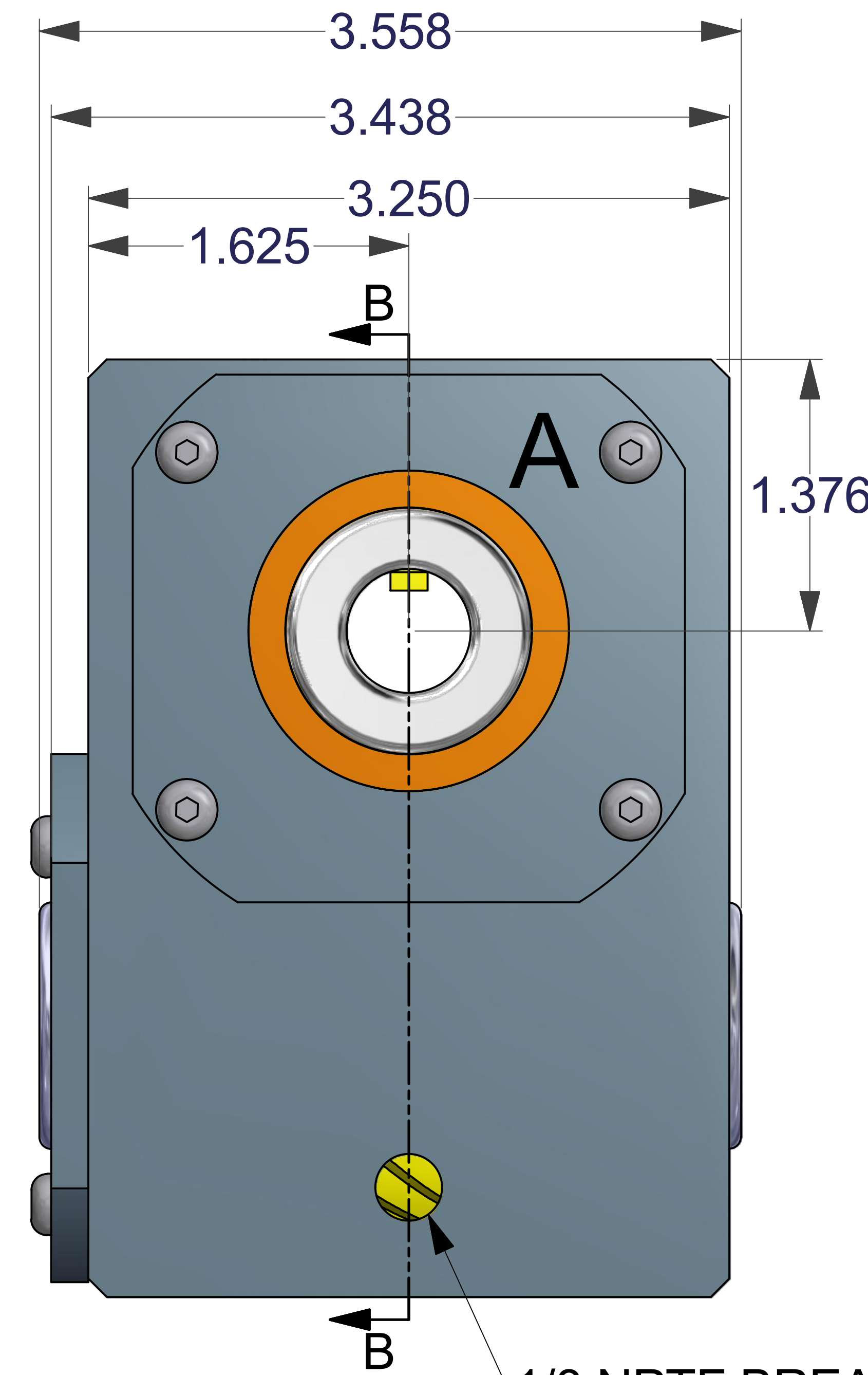

1/8 NPTF BREATHER / FILL PORTS (2)

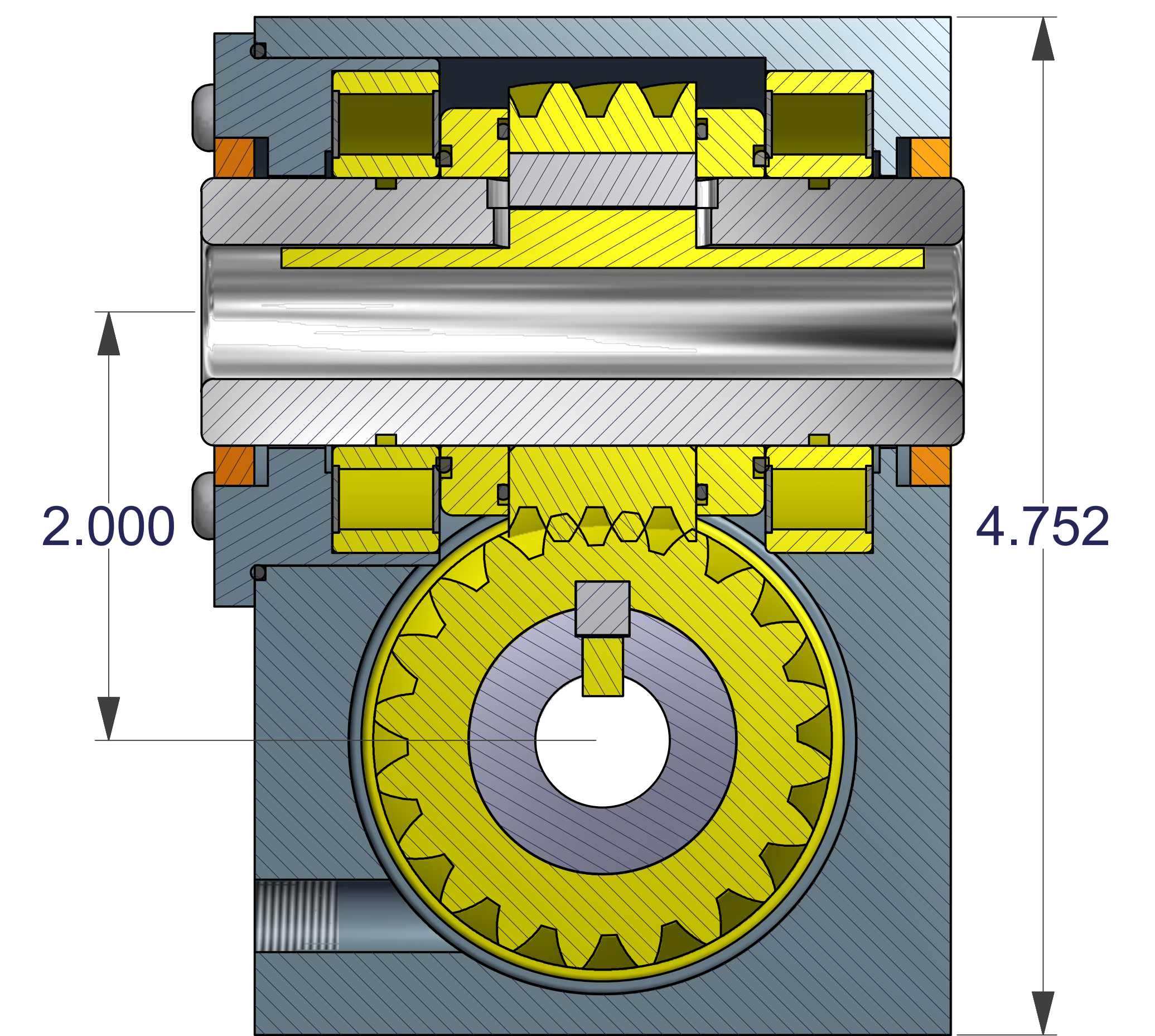

SECTION B-B
 SCALE 2

| | | | |
|---|--|---------------------------------------|----------------------------|
| UNLESS OTHERWISE SPECIFIED: DO NOT SCALE DRAWING REMOVE ALL BURRS TAP DEPTHS FULL THD. DRILL DEPTHS FULL DIA. | THIRD ANGLE PROJECTION | W.C. BRANHAM INC. RIVER FALLS, WI. | |
| | DESIGNER WCB | | DATE 10/23/10 |
| | TOLERANCES 2 PLACE +/- .010 3 PLACE +/- .005 | CHECKER | TITLE 20T CRL SERIES |
| | THREADS EXTERNAL CLASS 2A INTERNAL CLASS 2B | SCALE | DRAWING NO. |
| | CLASS | REVISION | |

SIZE
E