

PART NUMBER	TYPE	A-BORE	B-BORE	T-O-M PART NUMBER
4304-0820	RH	1.25	1.25	0230-0400
4304-0821	LH	1.25	1.25	0231-0400
4304-0822	RH	1.0	1.25	0228-0400
4304-0823	LH	1.0	1.25	0229-0400
4304-0824	RH	1.0	1.0	0226-0400
4304-0825	LH	1.0	1.0	0227-0400
4304-0826	RH	.750	1.25	0224-0400
4304-0827	LH	.750	1.25	0225-0400
4304-0828	RH	.750	1.0	0222-0400
4304-0829	LH	.750	1.0	0223-0400
4304-0830	RH	.750	.750	0220-0400
4304-0831	LH	.750	.750	0221-0400
4304-0852	RH	1.50	1.50	
4304-0853	LH	1.50	1.50	
4304-0854	RH	1.50	1.25	
4304-0855	LH	1.50	1.25	
4304-0856	RH	1.50	1.0	
4304-0857	LH	1.50	1.0	

INPUT TORQUE = OUTPUT TORQUE / .6, IN. LBS.

RPM OUTPUT TORQUE, IN. LBS.

33	358
50	312
100	248
200	198
300	172
400	122
500	111
1000	90
1200	85

MAX. HAND TORQUE - 609 IN. LBS.

- \* 8620 HEAT TREATED GEARS
- \* (4) DBL. SEALED R24 BALL BEARINGS
- \* ANODIZED ALUMINUM HOUSING & CAPS
- \* PREFILLED WITH MAGNALUBE 'G' GRADE 2
- \* SHAFT SEALS AVAILABLE WITH RECIRCULATING LUBRICANT (CRL SERIES)

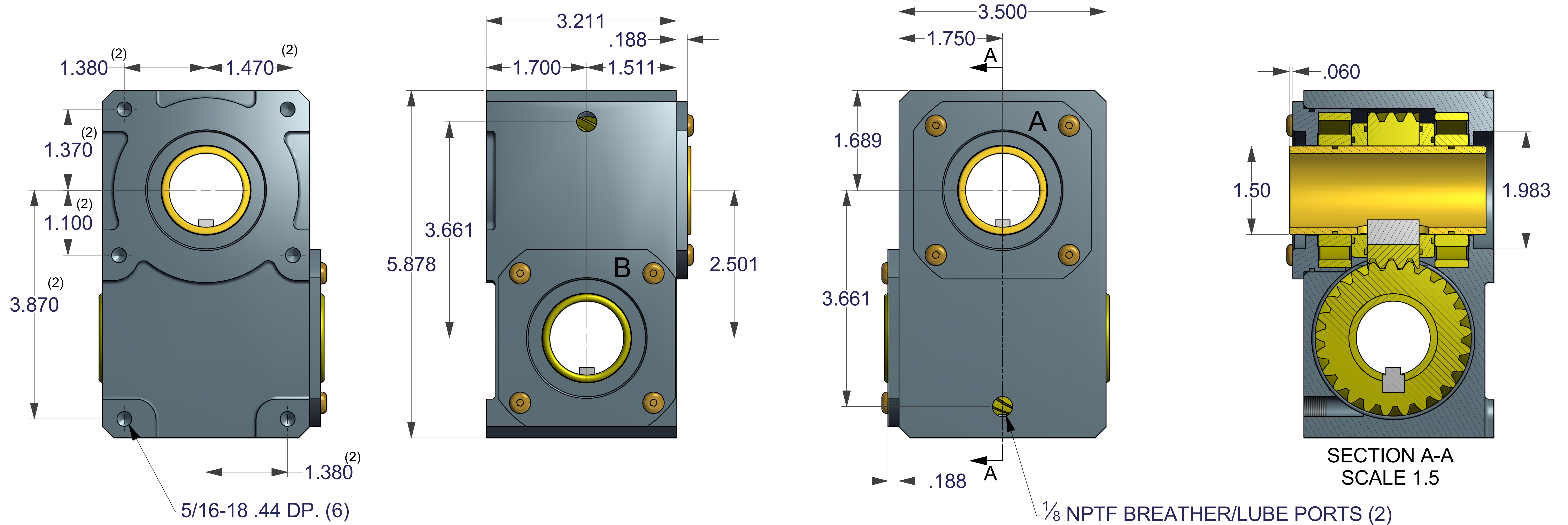

KEY SIZES: 3/4 BORE -- 3/16  
 1.0 BORE -- 1/4  
 1 1/4 BORE -- 1/4  
 1 1/2 BORE -- 3/8

T-O-M (S/R) INTERCHANGE SERIES  
 MOUNTING & CENTERLINE INTERCHANGEABLE  
 T-O-M REFERS TO "THE OTHER MANUFACTURES"  
 BRAND OF HAMEL, MINNESOTA

UNLESS OTHERWISE SPECIFIED		THIRD ANGLE PROJECTION		W.C. BRANHAM INC.	
DO NOT SCALE DRAWING REMOVE ALL BURRS TAP DEPTHS FULL THD. DRILL DEPTHS FULL DIA.				RIVER FALLS, WI.	
TOLERANCES 2 PLACE +/- .010 3 PLACE +/- .005		DESIGNER WCB 07-12-11	DATE	TITLE GLIDE-RIGHT SERIES	
THREADS EXTERNAL CLASS 2A INTERNAL CLASS 2B		CHECKER	DATE	1:1 BASE MOUNT	
SCALE		CLASS		DRAWING NO.	REVISION

SIZE  
E