

PART NUMBER	RATIO	ROTATION	A-BORE	B-BORE
4306-0002	1:1 ALL	R.H.	5/8	5/8
4306-0003		L.H.	5/8	5/8
4306-0004		R.H.	3/4	3/4
4306-0005		L.H.	3/4	3/4
4306-0006		R.H.	1.0	1.0
4306-0007		L.H.	1.0	1.0
4306-0008		R.H.	5/8	3/4
4306-0009		L.H.	5/8	3/4
4306-0010		R.H.	5/8	1.0
4306-0011		L.H.	5/8	1.0
4306-0012		R.H.	3/4	1.0
4306-0013		L.H.	3/4	1.0
4306-0014		R.H.	3/4	5/8
4306-0015		L.H.	3/4	5/8
4306-0016		R.H.	1.0	5/8
4306-0017		L.H.	1.0	5/8
4306-0018		R.H.	1.0	3/4
4306-0019		L.H.	1.0	3/4

- * PREFILLED WITH MAGNALUBE 'G' GRADE 2
- * 8620 HEAT TREATED 20 TOOTH GEARS
- * (4) R20 DBL. SEALED BALL BEARINGS
- * ALUM. HOUSING & CAPS, BLACK ANODIZED
- * ELECTRO NICKEL PLATING, STAINLESS
- FASTENERS & SHAFT SEALS AVAILABLE
- * STAINLESS HOUSINGS, CAPS & BEARINGS AVAILABLE
- * METRIC BORE SIZES & METRIC THREADS AVAILABLE

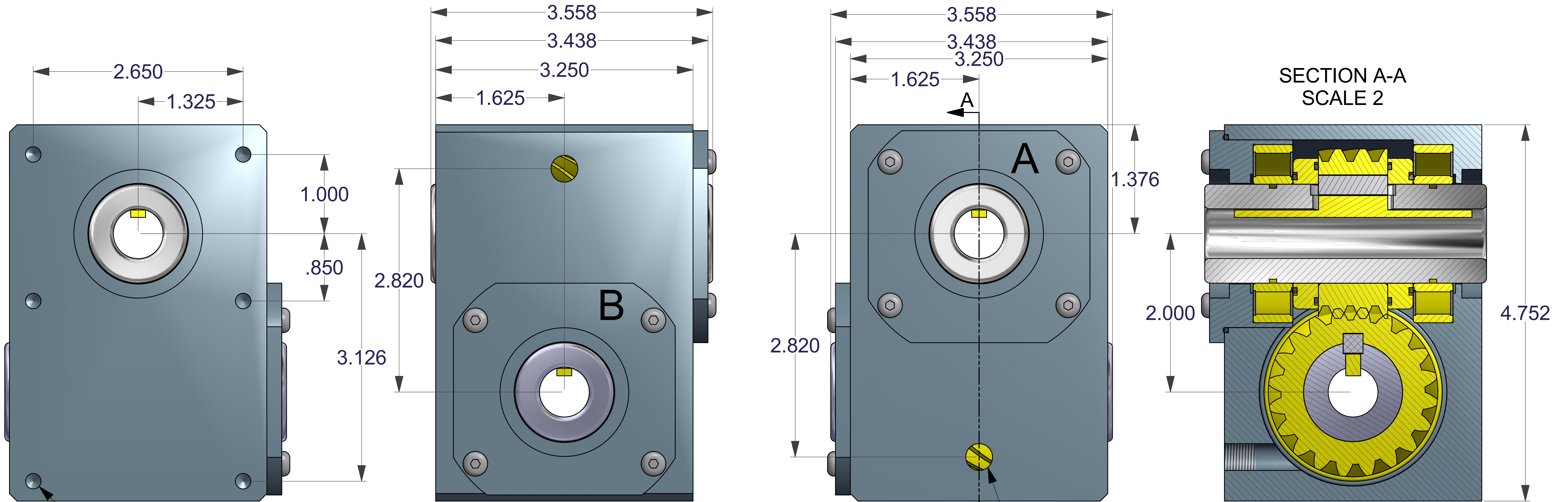

1/4-20 .44 DP. (6)

MAX. HAND TORQUE -- 402 IN. LBS.
 INPUT TORQUE = OUTPUT TORQUE/.6
 RPM OUTPUT TORQUE, IN. LBS.

33	236
50	205
100	163
200	130
300	113
400	80
500	73
1000	59
1200	56

KEY SIZES
 5/8 BORE - 3/16
 3/4 BORE - 3/16
 1.0 BORE - 1/4

1/8 NPTF BREATHER / FILL PORTS (2)

UNLESS OTHERWISE SPECIFIED: DO NOT SCALE DRAWING REMOVE ALL BURRS TAP DEPTHS FULL THD. DRILL DEPTHS FULL DIA.	THIRD ANGLE PROJECTION	DESIGNER WCB	DATE 10/23/10	TITLE 20T IAS SERIES	DRAWING NO.	REVISION
	TOLERANCES 2 PLACE +/- .010 3 PLACE +/- .005		CHECKER			
	THREADS EXTERNAL CLASS 2A INTERNAL CLASS 2B	SCALE	W.C. BRANHAM INC. RIVER FALLS, WI.			
	CLASS		SIZE E			