

PART NUMBER	RATIO	TYPE	A-BORE	B-BORE
4305-0080	2:1 ALL	RH	30	20
4305-0081		LH	30	20
4305-0082		RH	25	20
4305-0083		LH	25	20
4305-0084		RH	20	20
4304-0085		LH	20	20

INPUT TORQUE = OUTPUT TORQUE/1.24, IN. LBS.

RPM	OUTPUT TORQUE, IN. LBS.
33	369
50	320
100	256
200	203
300	176
400	126
500	115
1000	92
1200	70

MAX. HAND TORQUE = 609 IN. LBS.

KEY SIZES: BORE -- WIDTH

20	6mm
25	8mm
30	8mm

- * 8620 HEAT TREATED GEARS
- * (2) R24 DBL. SEALED BALL BEARINGS
- * (2) R16 DBL. SEALED BALL BEARINGS
- * ANODIZED ALUM. HOUSING & CAPS
- * PREFILLED WITH MAGNALUBE 'G' GRADE 2
- * ALL STAINLESS & WASHDOWN VERSIONS AVAILABLE

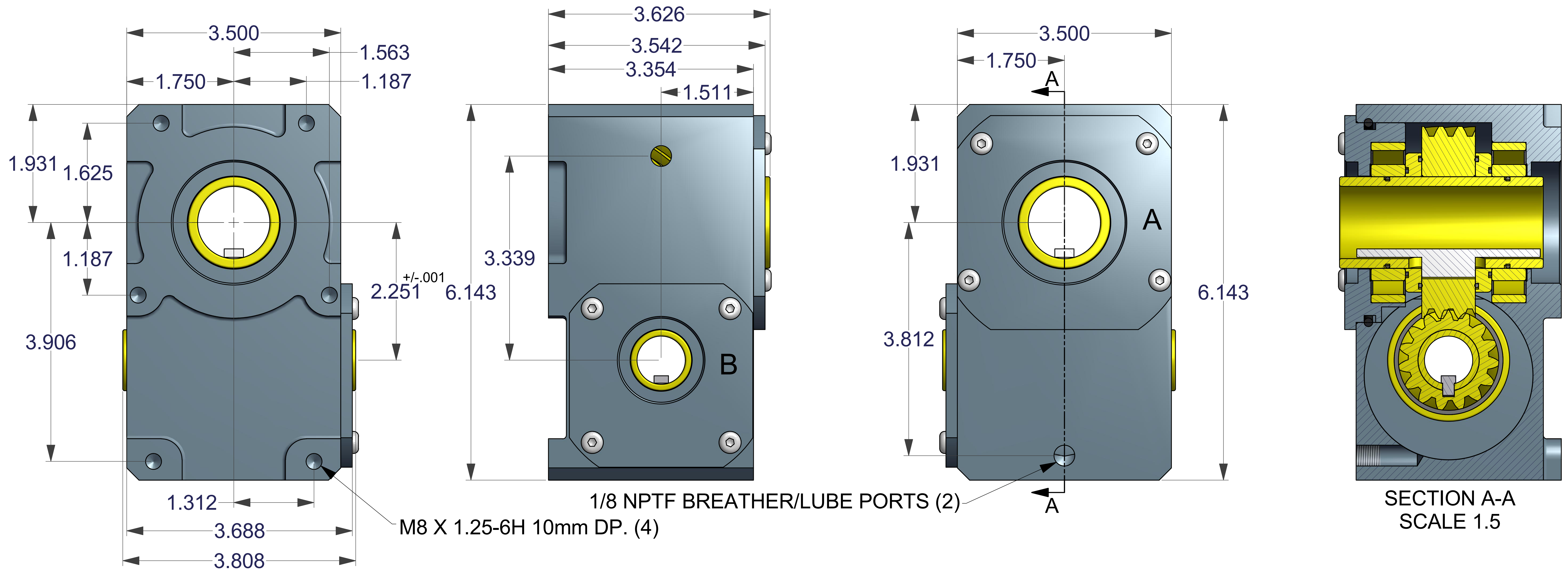

UNLESS OTHERWISE SPECIFIED: DO NOT SCALE DRAWING REMOVE ALL BURRS TAP DEPTHS FULL THD. DRILL DEPTHS FULL DIA.		THIRD ANGLE PROJECTION	W.C. BRANHAM INC. RIVER FALLS, WI.
TOLERANCES 2 PLACE +/- .010 3 PLACE +/- .005	DESIGNER WCB	DATE 02/05/11	TITLE BASE MOUNT METRIC 2:1 SERIES
THREADS EXTERNAL CLASS 2A INTERNAL CLASS 2B	CHECKER	DATE	DRAWING NO. 4305-0080
	SCALE	CLASS	REVISION E