

INPUT TORQUE = OUTPUT TORQUE/.60
 OUTPUT TORQUE, IN. LBS.

RPM 1:1 RATIO

33	59
50	51
100	41
150	36
200	32
300	28
400	21
500	19
1000	15
1200	14
1800	12

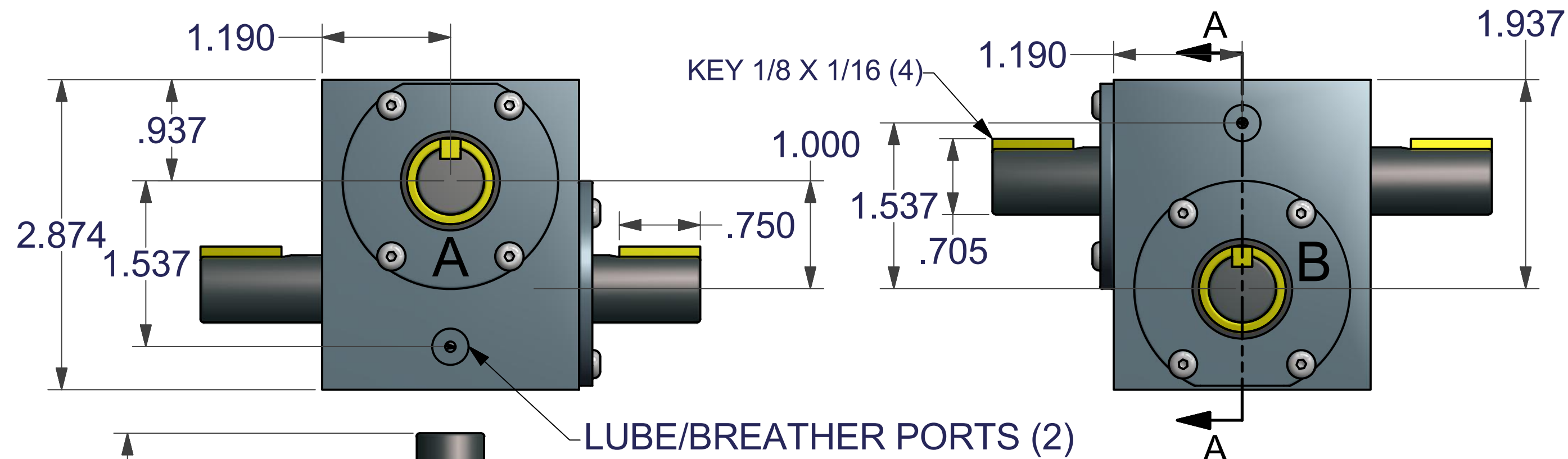
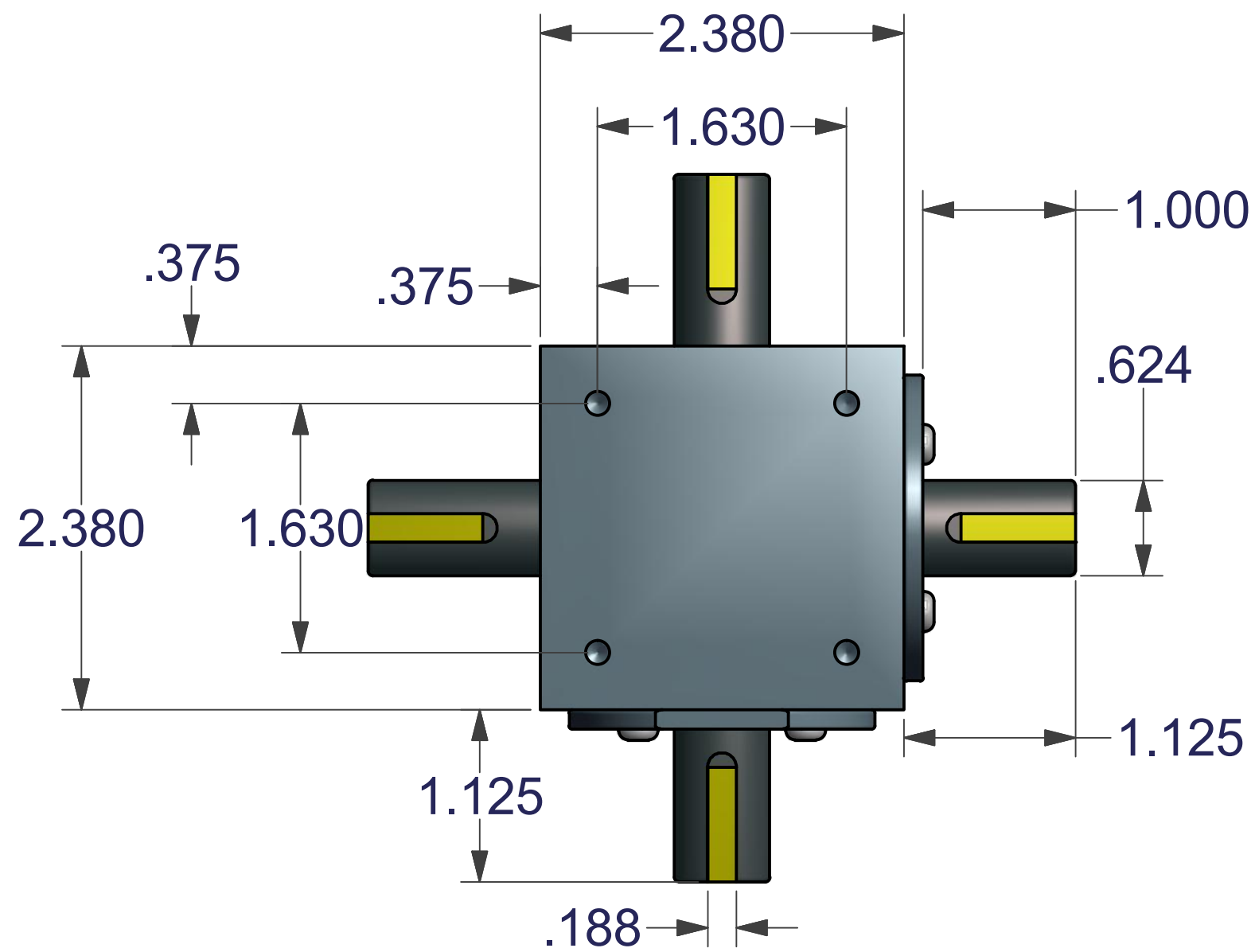
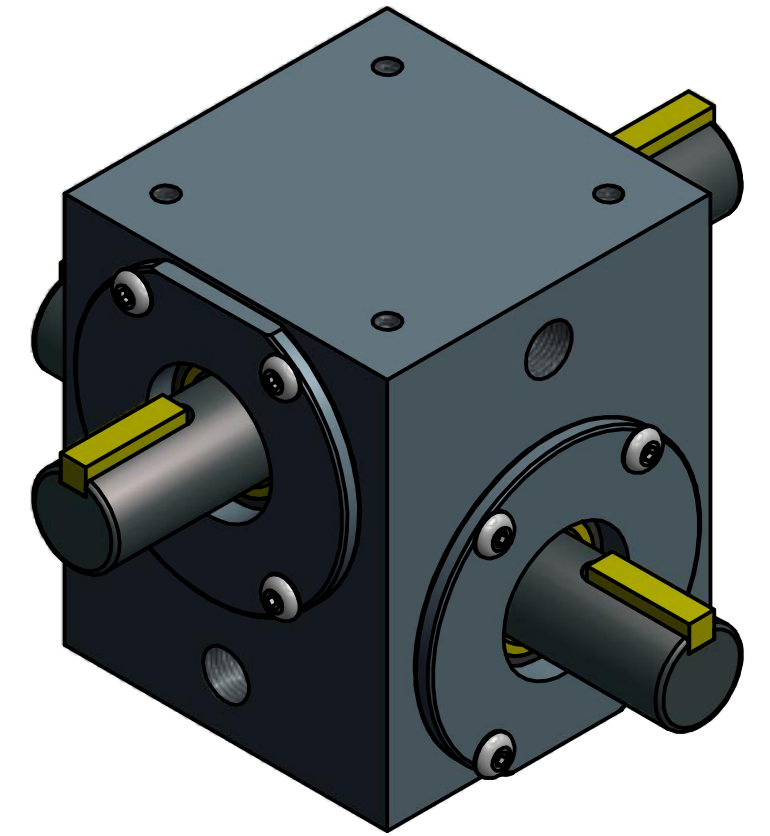

SECTION A-A
 SCALE 1 : 1

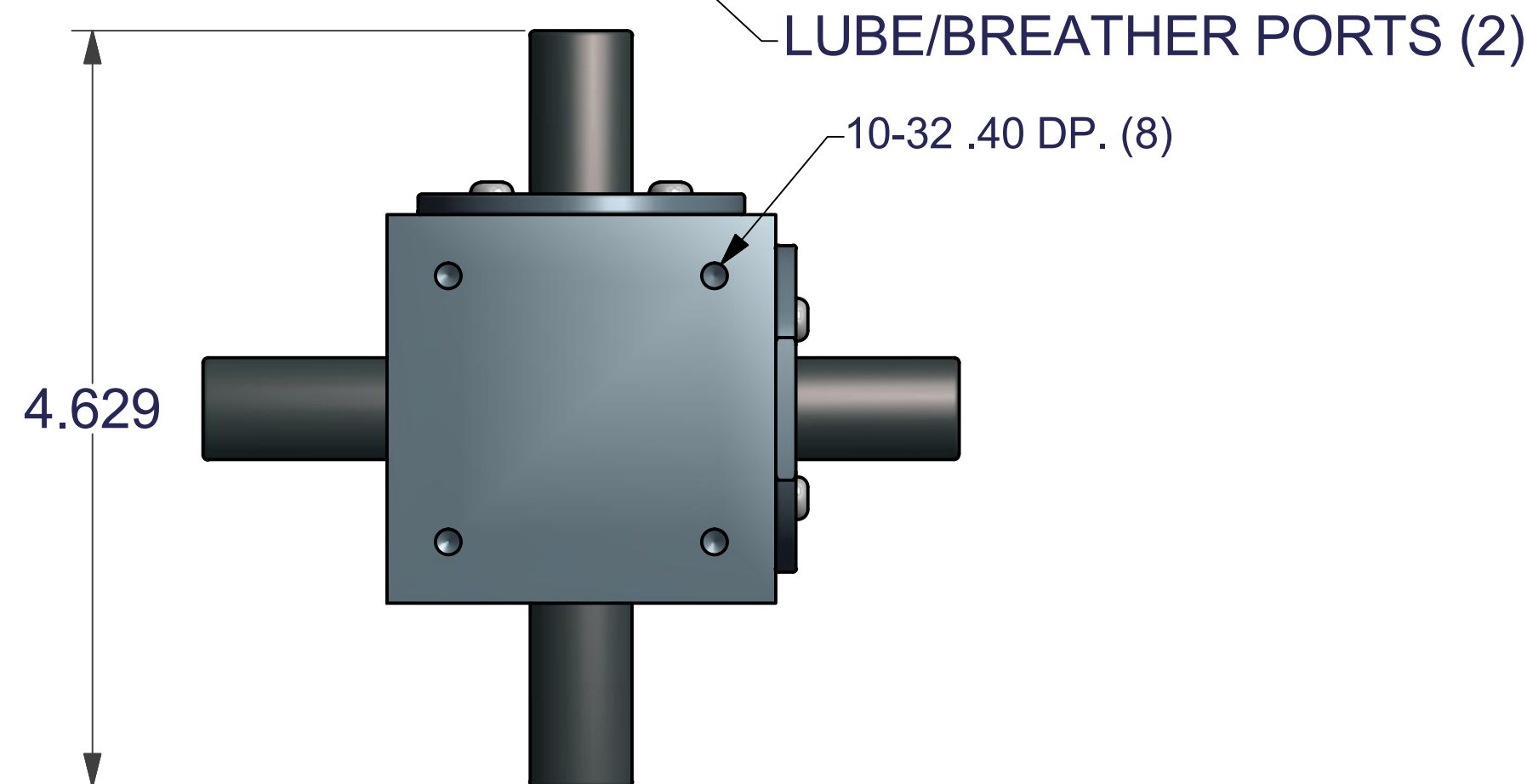
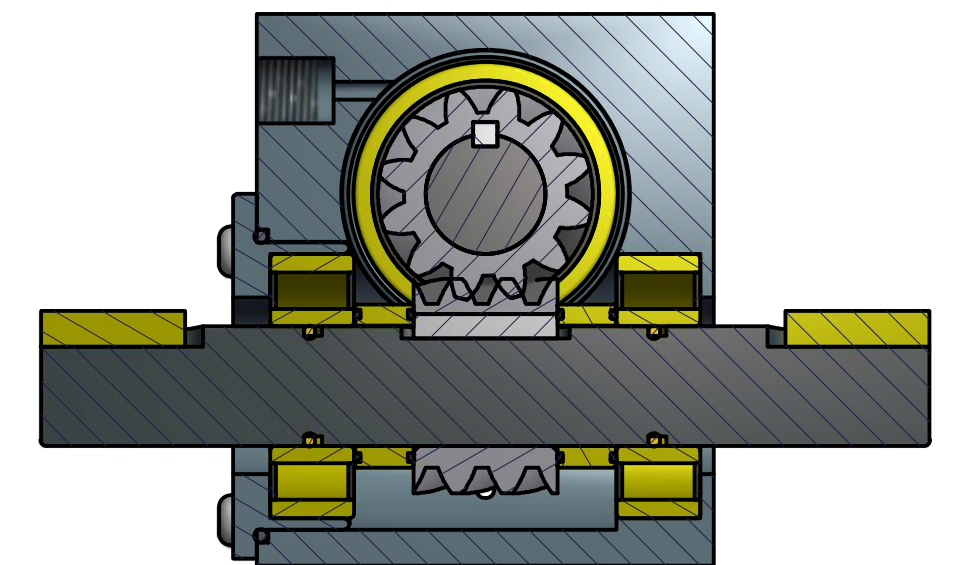

PREFILLED WITH MAGNALUBE G GRADE 2
 WASHDOWN VERSIONS AVAILABLE
 LEFT HAND VERSION P/N 4304-0175

SIZE
C

UNLESS OTHERWISE SPECIFIED DO NOT SCALE DRAWING REMOVE ALL BURRS TAP DEPTHS FULL THD. DRILL DEPTHS FULL DIA.	THIRD ANGLE PROJECTION		W.C. BRANHAM INC. RIVER FALLS, WI.
	DESIGNER WCB	DATE 03/13/09	
TOLERANCES 2 PLACE +/- .010 3 PLACE +/- .005	CHECKER	DATE	DRAWING NO. 4304-0174
THREADS EXTERNAL CLASS 2A INTERNAL CLASS 2B	SCALE	CLASS	REVISION